

PUNTE SPECIALI PER FORI PASSANTI IN HW

HW Special through hole drill bits

HW Spezialdurchgangsbohrer

HW Broca para agujero pasante

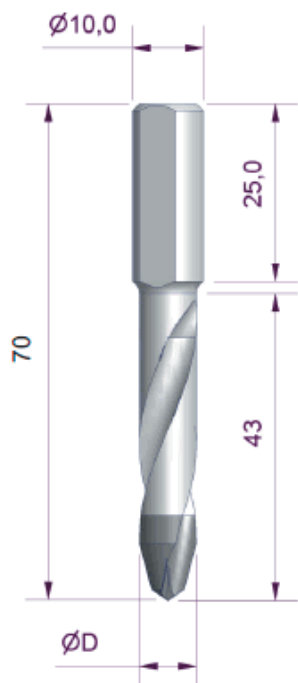

Ø D	L	DX - RH	SX - LH
5	70	FP.SB.HP.70/5D	FP.SB.HP.70/5.S
6	70	FP.SB.HP.70/6D	FP.SB.HP.70/6.S
8	70	FP.SB.HP.70/8D	FP.SB.HP.70/8.S

PUNTE SPECIALI PER FORI PASSANTI IN HW INTEGRALE

HW Solid carbide special through hole drill bits

HW Spezialdurchgangsbohrer

HW Integral broca para agujero pasante

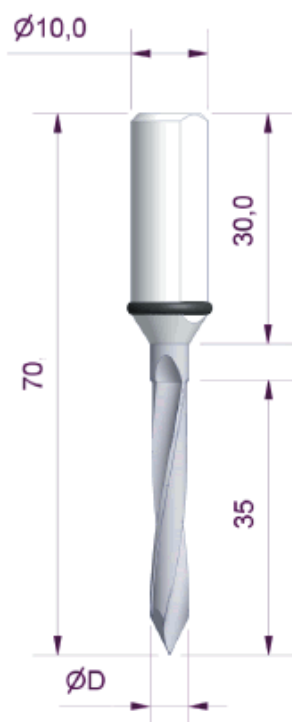

Ø D	L	DX - RH	SX - LH
5	70	FP.W.70/5.D	FP.W.70/5.S
6	70	FP.W.70/6.D	FP.W.70/6.S
8	70	FP.W.70/8.D	FP.W.70/8.S

PUNTE SPECIALI PER FORI PASSANTI IN HW INTEGRALE HIGH PERFORMANCE

HM Solid carbide special through hole drill bits

VHM Spezialdurchgangsbohrer

HW Integral broca para agujero pasante

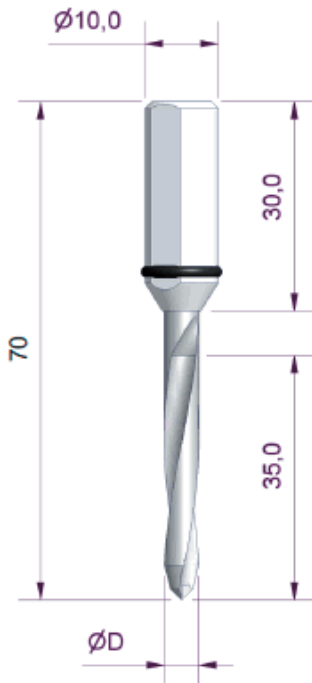

Ø D	L	DX - RH	SX - LH
5	70	FP.W.HP.70/5.D	FP.W.HP.70/5.S
6	70	FP.W.HP.70/6.D	FP.W.HP.70/6.S
8	70	FP.W.HP.70/8.D	FP.W.HP.70/8.S

PUNTE COMPONENTI PER FORI PASSANTI IN HW INTEGRALE

HW Jobber drill bits

VHM Vollhartmetall Spiralbohrer

Broca MD integral

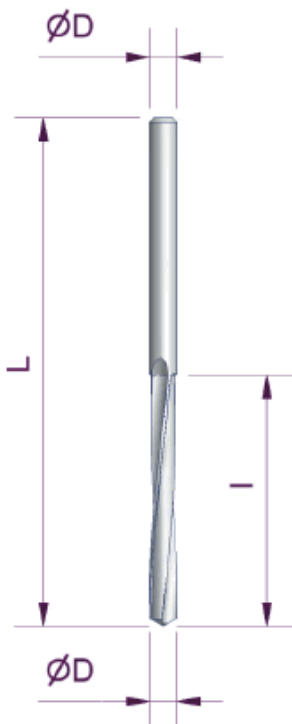

Ø D	L	DX - RH	SX - LH
2	49	FP.W.49/2.D	FP.W.49/2.S
2.5	55	FP.W.55/25.D	FP.W.55/25.S
3	55	FP.W.55/3.D	FP.W.55/3.S
3.2	55	FP.W.55/32.D	FP.W.55/32.S
3.5	55	FP.W.55/35.D	FP.W.55/35.S
4	55	FP.W.55/4.D	FP.W.55/4.S
5	55	FP.W.55/5.D	FP.W.55/5.S